

C65 Microturbine

Digester Gas

Achieve ultra-low emissions and reliable electrical generation from digester gas.

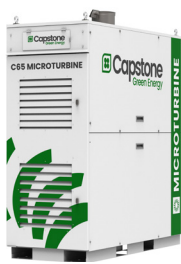

C65 Microturbine

Electrical Performance⁽¹⁾

Electrical Power Output	65kW
Voltage	400/480 VAC
Electrical Service	3-Phase, 4 Wire Wye
Frequency	50/60 Hz
Electrical Efficiency LHV	28%

Fuel/Engine Characteristics⁽¹⁾

Digester Gas HHV	20.5–32.6 MJ/m ³ (550–875 BTU/scf)
H ₂ S Content	< 5,000 ppmv
Inlet Pressure	517–551 kPa gauge (75–80 psig)
Fuel Flow HHV	919 MJ/hr (871,000 BTU/hr)
Net Heat Rate LHV	12.9 MJ/kWh (12,200 BTU/kWh)

Exhaust Characteristics⁽¹⁾

NO _x Emissions @ 15% O ₂	< 9 ppmvd (18 mg/m ³)
Exhaust Mass Flow	0.49 kg/s (1.08 lbm/s)
Exhaust Gas Temperature	329°C (625°F)

Benefits

- Ultra-low emissions
- Accepts sour gas fuels with up to 5,000 ppm H₂S
- One moving part – minimal maintenance and downtime
- Patented air bearings – no lubricating oil or coolant
- Integrated utility synchronization – no external switchgear
- Compact modular design allows for easy, low-cost installation
- Multiple units easily combined – act as single generating source
- Remote monitoring and diagnostic capabilities
- Proven technology with tens of millions of operating hours
- Various Factory Protection Plans available

**Smarter Energy
for a Cleaner Future**

Dimensions & Weight⁽²⁾

Width x Depth x Height	0.76 x 1.95 x 2.08 m (30 x 77 x 82 in)
Weight - Grid Connect Model	758 kg (1,671 lb)
Weight - Dual Mode Model	1,121 kg (2,471 lb)

Minimum Clearance Requirements⁽³⁾

Horizontal Clearance	
Left & Right	0.76 m (30 in)
Front - Grid Connect Model	0.76 m (30 in)
Front - Dual Mode Model	1.65 m (65 in)
Rear	0.91 m (36 in)

Acoustic Emissions

Nominal at Full Power at 10 m (33 ft)⁽⁴⁾ | 70 dBA

Certifications

- UL 2200 Listed
- CE Certified
- Certified to the following grid interconnections standards: UL 1741-SA, VDE, BDEW, CEI 0-16, AS4777
- Compliant to California Rule 21

C65 Engine Components

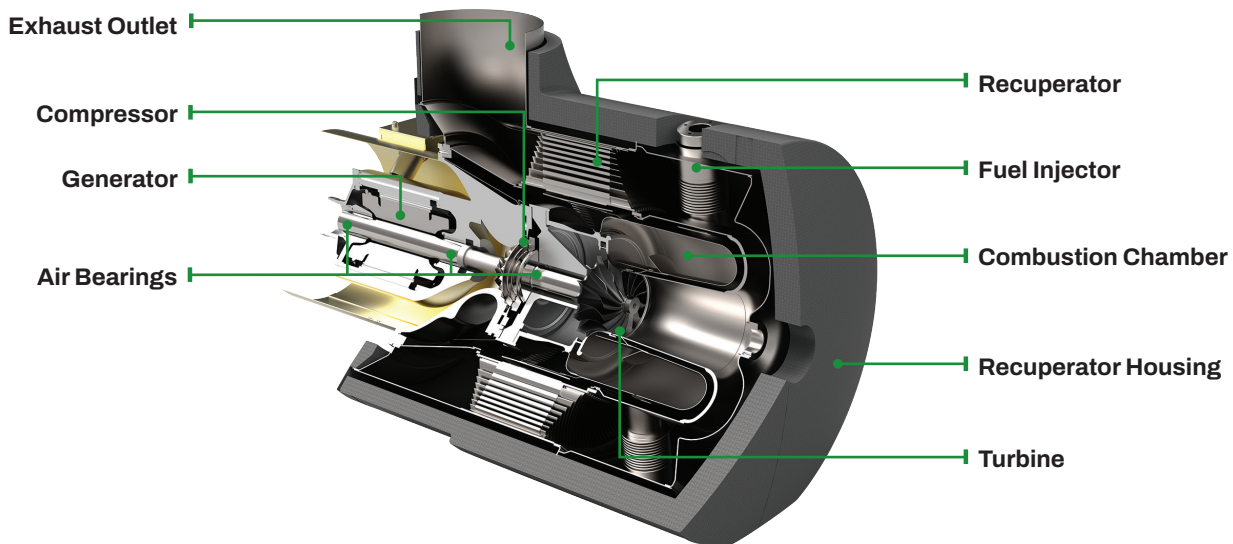

(1) Nominal full power performance at ISO conditions: 15°C (59°F), 14.696 psia, 60% RH

(2) Approximate dimensions and weights

(3) Clearance requirements may increase due to local code considerations

(4) The optional acoustic inlet hood kit can reduce acoustic emissions at the front of the Microturbine as much as 5 dBA

Specifications are not warranted and are subject to change without notice.